

# THE SPIRITS BUSINESS

THE ONLY INTERNATIONAL TRADE  
MEDIA SOLELY DEDICATED TO SPIRITS

A central image of a glass of whiskey with ice and a splash of liquid against an orange background. The glass is a heavy, textured tumbler with a large ice cube. The liquid is splashing upwards and outwards, creating a dynamic scene. The background is a solid, vibrant orange color.

**MEDIA PACK 2026**

# A NOTE FROM THE EDITOR-IN-CHIEF

As the world's only international trade publication dedicated to spirits, *The Spirits Business* takes pride in bringing you nothing but the highest-quality journalism



The funny thing about working in media is that time often feels as though it's stuck on fast-forward. We're constantly looking ahead, planning future issues of *The Spirits Business* long before they reach our readers, and then, in what feels like the blink of an eye, another year has already raced by. What's become apparent in recent years is the spirits industry never really slows down – and neither do we.

From investments, mergers and acquisitions to exclusive interviews, in-depth category analysis, data and industry trends, *The Spirits Business* remains unrivalled in keeping the trade informed with need-to-know news.

As the world's only global trade publication dedicated solely to spirits, we take pride in keeping the industry informed with timely, essential reporting. Our award-winning journalists go directly to the source to deliver the most accurate and relevant updates from around the world.

There are many ways to stay connected with the latest industry developments: our monthly print magazine, [www.thespiritsbusiness.com](http://www.thespiritsbusiness.com), our daily global newsletter, our US-focused newsletter, and our app. In 2026, our readers can expect further deep dives into individual spirits categories and regions, in addition to insightful features and stories about the on-trade, which are covered in the Back Bar section of the magazine.

Furthermore, we offer a number of in-depth reports throughout the year to give additional insights to the trade. These include the *Global Travel Retail Report*, *World Spirits Report*, and *Global Bar Report*. Most notably, our *Brand Champions* supplement, compiled in-house by *The Spirits Business* editorial team, offers extensive analysis about the world's million-case-selling spirits brands. Plus, we offer compelling interviews on *The Spirits Business Podcast*.

In addition, our experienced events team strives to reward the best spirits on the market through The Global Spirits Masters Competitions, a blind-tasting series judged by independent tasters – unique in the industry.

I'm proud to chair The Global Spirits Masters Competitions – and to lead our talented editorial team at *The Spirits Business*. We are unwavering in our passion for the industry, and dedicated to providing the most interesting and useful articles for the global trade. We are well-equipped and excited to work with our media partners to help you reach your goals in 2026.

**MELITA KIELY**

Editor-in-Chief

*The Spirits Business*



## PRINT READERSHIP & CIRCULATION

*The Spirits Business* is the only international trade magazine and website in the world that is dedicated to spirits. The circulation of both print and digital copies is up to 13,000 copies per month across 120 countries, reaching more than 50,000 spirits professionals worldwide.

### Readership

Our global audience comprises the biggest retailers, distributors, wholesalers and duty free buyers in the business. Furthermore, *The Spirits Business* reaches thousands of world-class bartenders and bar owners around the globe.

### Bonus distribution

In addition to our regular subscribers, we are also distributed at all the major trade shows and events:

- ProWein, Düsseldorf
- WSWA Access Live
- IAADFS Duty Free & Travel Retail Summit of the Americas
- TFWA Asia Pacific Exhibition & Conference
- Wine Paris
- Tales of the Cocktail
- BCB Brooklyn, BCB Berlin, BCB London
- TFWA World Exhibition & Conference, Cannes
- London Cocktail Week

### Readership

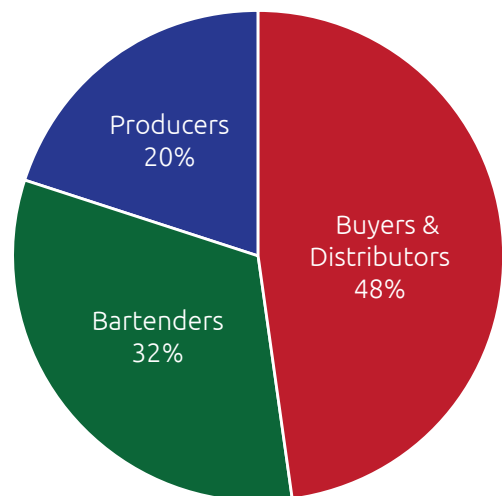

### Top 15 countries

UK	Spain	Hong Kong
Germany	Ireland	Belgium
France	Canada	Finland
US	Portugal	Russia
Italy	Bulgaria	Mexico



## WEB & SOCIAL

Updated daily with relevant and timely news, interviews and features from the global drinks industry, *thespiritsbusiness.com* is viewed by more than four million visitors per year.

With numerous display and sponsorship opportunities across both our websites and newsletters, brands can access a cost-effective platform with *The Spirits Business* to target our expanding global online readership.

In addition, we reach and influence thousands of followers every day via social media. Whether it is X (formerly Twitter), Instagram, Threads, Facebook or LinkedIn, we are constantly engaged with key industry figures and consumers.

### Monthly stats:

More than four million visitors per year, from 195 countries

### Newsletters:

- *The Spirits Business* Daily Newsletter (Monday to Friday) is mailed to just over 26,000 opted-in recipients around the world, with an average 26% open rate
- The American Pour is our US-only newsletter, mailed every Tuesday and Thursday to just over 9,000 opted-in recipients in the US, with an average 29% open rate
- The SB Digestif is our weekly Friday roundup of the biggest weekly stories, reaching almost 23,000 opted-in subscribers

Our daily newsletters are researched and written every day by our team of award-winning journalists, before being sent out to our global subscribers. We pride ourselves on delivering the most up-to-date and interesting news and insights, with no aggregated content. Clients also have the opportunity to run solus newsletters to our database, which focus solely on your brand, product(s) and/or a specific call to action.

### Social media:

- 30K followers on The Spirits Business X/Twitter account
- 22K followers on The Spirits Business Facebook account
- 20.3K followers; 150+ likes per post on The Spirits Business Instagram account
- 130K followers on The Spirits Business LinkedIn page
- More than 202k followers on our social media platforms in total, and growing daily

### Top 20 countries

US	The Netherlands
UK	France
India	Mexico
Canada	Spain
Singapore	Italy
China	UAE
Ireland	Japan
Australia	Sweden
South Africa	Malaysia
Germany	New Zealand

# WEBSITE ANALYSIS & INSIGHTS 2025

Source: Similarweb



## Traffic & Engagement



## Engagement

Metric	thespiritsbusiness.com	drinksint.com	drinks-intel.com	harpers.co.uk
Monthly visits	376,816 🏆	44,954	32,351	20,848
Monthly unique visitors	233,131 🏆	23,948	17,795	10,978
Visits / Unique visitors	1.62	1.88	1.82	1.90 🏆
Deduplicated audience	211,424 🏆	21,288	15,745	9,658
Visit duration	00:00:45 🏆	00:00:39	00:00:29	00:00:22
Pages per visit	1.73	1.94 🏆	1.64	1.47
Bounce rate	55.24%	42.31% 🏆	45.14%	53.23%
Page Views	652,160 🏆	87,117	53,047	30,548

# WEBSITE ANALYSIS & INSIGHTS 2025

Source: Similarweb

## Visits over time

Aug 2025 - Oct 2025 Worldwide All traffic

thespiritsbusiness.com  drinksint.com  drinks-intel.com  harpers.co.uk

1.130M

134,863

97,054

62,543

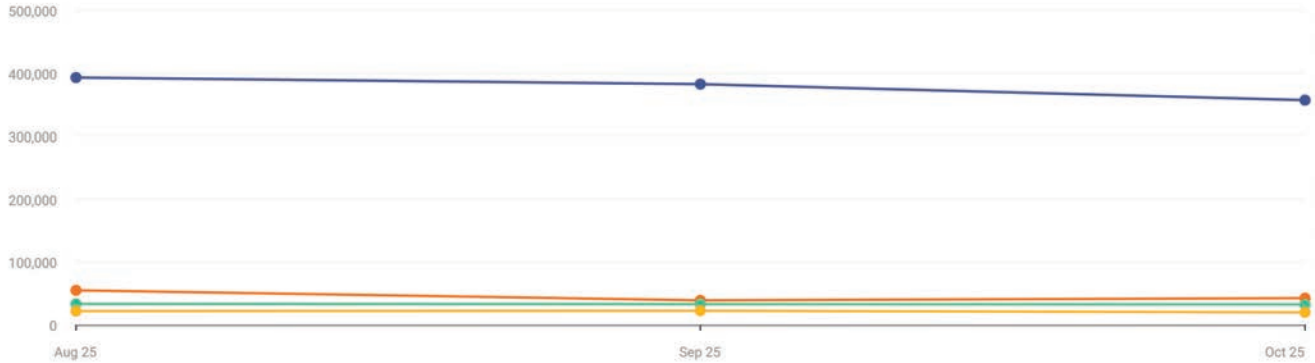

## Referrals

### Top referring websites

Aug 2025 - Oct 2025 Worldwide Desktop

Domain	Website Categories	Traffic Share	Group Traffic Share Split
chatgpt.com	AI Chatbots and Tools	31.62%	70.2% 13.3% 12.0%
coveragebook.com	Marketing and Advertising	11.71%	87.1% 12.9%
globalspiritsmasters.com	Unknown	9.75%	100%
claude.ai	AI Chatbots and Tools	4.74%	76.2% 23.8%
perplexity.ai	AI Chatbots and Tools	4.13%	97.0%

# FEATURES LIST

As the must-read publication for the international spirits trade, our 2026 features list is more varied than ever before. Spanning established categories such as Scotch, gin and vodka to up-and-coming disruptive sectors, plus numerous global reports, our schedule will help you plan your most effective marketing strategy yet.

Month	Features	Awards results	Additional distribution
January	<b>Most Innovative Spirits list</b> Spirits trends to watch Category reports: Japanese whisky; RTDs	The Low & No Masters; Taste Masters 2024	WSWA Access Live
February	<b>The Tequila issue</b> Category reports: Tequila; Mezcal; Low/no-alcohol Regional report: UK Gin in travel retail Show preview: Wine Paris		Wine Paris; BCB Singapore
March	<b>The Rum issue</b> Category reports: Rum; Third-party spirits; Distributors/Importers Regional report: South Africa Show previews: IAADFS Summit of the Americas; ProWein	The Rum & Cachaça Masters	IAADFS Summit of the Americas; ProWein, Düsseldorf
April	<b>The Vodka issue</b> Category reports: Vodka; Tonics and mixers; Vermouth Regional report: Eastern Europe Tequila in travel retail Show preview: TFWA Asia	The Tequila & Mezcal Masters; The DB & SB Spring Blind Tasting	TFWA Asia
May	<b>The Asia issue</b> Category reports: Asian spirits; Cognac; Brandy Regional reports: Asia; US Irish whiskey in travel retail Show preview: BCB Brooklyn; BCB London; London Wine Fair	The Cognac Masters; The Brandy Masters; The Asian Spirits Masters	BCB Brooklyn; BCB London; London Wine Fair
June	<b>The Brand Champions 2026*</b> Category reports: Hard seltzers; SaaS/Software; Rum; RTDs Regional report: Western Europe Vodka in travel retail	The Pre-Mixed, RTD & Hard Seltzer Masters	
July	<b>The Gin issue</b> Category reports: Gin; Sustainability; Apéritifs Regional report: Middle East & Africa Show preview: Tales of the Cocktail	The Tonic & Mixer Masters; The Gin Masters – First Tasting	Tales of the Cocktail
August	<b>The Whisky issue</b> Category reports: Scotch whisky; World whisky; Spirits packaging Regional report: India	The Scotch Whisky Masters; The American Whiskey Masters; The Irish Whiskey Masters; The World Whisky Masters	
September	<b>The Travel Retail issue</b> Global travel retail report Category reports: Irish whiskey; Vodka; Rum Regional report: Australasia Show preview: TFWA World Exhibition & Conference	The Vodka Masters; The Travel Retail Masters	TFWA World Exhibition & Conference
October	<b>The Luxury Spirits issue</b> Category reports: Luxury spirits; American whiskey; Retailers; Low/no-alcohol Regional report: Scandinavia Show previews: BCB Berlin; London Cocktail Week	The Luxury Masters; The SB Autumn Blind Tasting	BCB Berlin
November	<b>The On-Trade issue</b> Global Bar Report Category reports: Liqueurs; Tonics and mixers; Indian whisky Regional report: South America	The Liqueur Masters; The Speciality Spirits Masters	
December	<b>World Spirits Report</b> Category reports: SaaS/Software; Sustainability; Gin; Spirits packaging Regional report: North America Rum in travel retail	The Design & Packaging Masters; The SB Awards; The Gin Masters – Second Tasting	

\* The definitive guide to spirits brands selling more than one million nine-litre cases per annum. The Brand Champions supplement will contain exclusive and comprehensive data on spirits brands' sales volumes, equipping industry professionals with unparalleled information relevant to this dynamic industry.



# THE SPIRITS BUSINESS PODCAST

Available to listen to on all major streaming platforms, including Apple Podcasts, Spotify and Amazon Music. Contact our commercial team to learn more about advertising and sponsorship opportunities.



# THE GLOBAL SPIRITS MASTERS COMPETITIONS 2026

Launched in 2008, The Global Spirits Masters Competitions rates and rewards excellence in spirits production, giving brands key differentiation in a crowded market.

Judging is divided into 22 separate competitions to ensure each spirit category is given the utmost attention by specialist judges.

The Global Spirits Masters Competitions is unique in its exclusive use of completely independent expert judges, including journalists, retail buyers, bartenders and educators. As such, entrants can rest assured that their product has been assessed constructively and without bias by our panels of professionals. Judges can award Silver, Gold and Master medals, as well as additional Taste Master awards for outstanding excellence.

## The Global Spirits Masters Competitions 2026

Masters	Entry deadline	Sample deadline	Judging	Results published
Low & No-Alcohol	22 November	29 November	December	January
Rum & Cachaça	17 January	28 January	February	March
Tequila & Mezcal	14 February	25 February	March	April
Cognac	14 March	25 March	April	May
Brandy	14 March	25 March	April	May
Asian Spirits	21 March	1 April	April	May
Pre-Mixed, RTD & Hard Seltzer	18 April	29 April	May	June
Tonic & Mixer	2 May	13 May	June	July
Gin (First Tasting)	16 May	27 May	June	July
Scotch Whisky	13 June	24 June	July	August
Irish Whiskey	13 June	24 June	July	August
American Whiskey	20 June	1 July	July	August
World Whisky	20 June	1 July	July	August
Vodka	18 July	29 July	August	September
Travel Retail	23 July	1 August	August	September
Luxury	15 August	26 August	September	October
Liqueur	19 September	30 September	October	November
Speciality	19 September	30 September	October	November
Gin (Second Tasting)	17 October	28 October	November	December
Design & Packaging	24 October	4 November	November	December
Low & No	14 November	25 November	December	January 2026

### The Spirits Business Blind Tastings 2026

The SB Spring Blind Tasting	21 February	4 March	March	April
The SB Autumn Blind Tasting	15 August	26 August	September	October

### Further competitions and awards by *The Spirits Business*

The Spirits Business Awards 2026	12 August	August	November
The Alan Lodge Young International Drinks Writer of the Year	12 August	August	November

**For more information contact Rhiannon Morris:**

**rhiannon.morris@thespiritsbusiness.com +44 (0) 207 803 2430**

**Or Peter Overall: peter@thedrinksbusiness.com +44 772 555 9880**

# THE SPIRITS BUSINESS AWARDS



## THE SPIRITS BUSINESS AWARDS 2026

The Spirits Business Awards aims to reward those driving excellence across the industry from retailers and distributors to marketers, brands, distillers and blenders. Judged by members of *The Spirits Business* editorial team and a panel of independent spirits experts, the awards are separated into five areas: Retail and Marketing, Sustainability and Innovation, Tourism, Products, and People.

Through these awards we want to recognise the people and brands who continue to push the boundaries of innovation – including those working hard behind the scenes.

### Categories

#### Retail & Marketing

- Spirits Retailer of the Year
  - E-Commerce
  - Specialist
  - Supermarket
- Spirits Distributor of the Year
- Spirits Bottler of the Year
- Best Spirits PR Company
- Best Marketing Campaign
- Best Event

#### Sustainability & Innovation

- Spirits Sustainability Award

- Ethical Award
- Innovation in Production
- Innovation in Packaging

#### Culture & Tourism

- Distillery Consumer Experience Award
- Bar of the Year

#### Products & Brands

- Best New Product
- Brand of The Year
  - Whisky/Whiskey
  - Gin

- Vodka
- Speciality (Low & No/ Liqueurs / Pre-Mixed/ Other)
- Tequila/ Mezcal
- Brandy/ Cognac
- Rum/ Cachaça

#### People

- Blender of the Year
- Distiller of the Year
- Young Achiever of the Year
- Bartender of the Year
- Lifetime Achievement Award

### Our sponsors:





## THE SB TRAVEL RETAIL BEACH PARTY

*The Spirits Business* has a thriving events portfolio, and part of that includes our annual The SB Travel Retail Beach Party, which takes place during the TFWA World Exhibition & Conference in Cannes, France.

Last year, we welcomed a record number of guests – more than 400 – to enjoy a broad selection of spirits, cocktails and wine as the sun set on the French Riviera.

In 2026, we will be returning for another unmissable evening of networking and celebration.

We have a number of sponsorship and partner opportunities available and would be delighted to discuss how we can work together with interested parties.





# PITCH & POUR

Pitch & Pour is the newly launched boutique communications studio working with the team behind *The Spirits Business* and *the drinks business*, created to give ambitious independents and SMEs access to world-class storytelling, editorial intelligence, and industry influence.

A NEW BOUTIQUE PR STUDIO FOR DRINKS.

Pitch & Pour blends seasoned PR specialists, editors and industry strategists into one streamlined offer: campaigns that don't chase coverage, but create relevance.

Through our partnership with *The Spirits Business* and *the drinks business*, Pitch & Pour offers access to the editorial teams shaping global drinks conversation. The result is storytelling built from the inside out: features, interviews and thought-leadership pieces.

#### Services include:

- Communications strategy & press office
- Awards strategy
- Influencer & partnerships
- Hosted tastings, masterclasses and press dinners

#### Experience behind every pour

Led by brand PR strategist Alex Holbrook, Pitch & Pour brings nearly 20 years' experience launching and shaping culturally sharp, commercially smart brands across drinks, hospitality and lifestyle.



WE WORK WITH  
INDEPENDENT  
PRODUCERS,  
CHALLENGER BRANDS  
AND START-UPS  
READY TO STEP INTO  
THE SPOTLIGHT.

[www.pitchandpourpr.com](http://www.pitchandpourpr.com)

# Technical specifications for **THE SPIRITS BUSINESS**

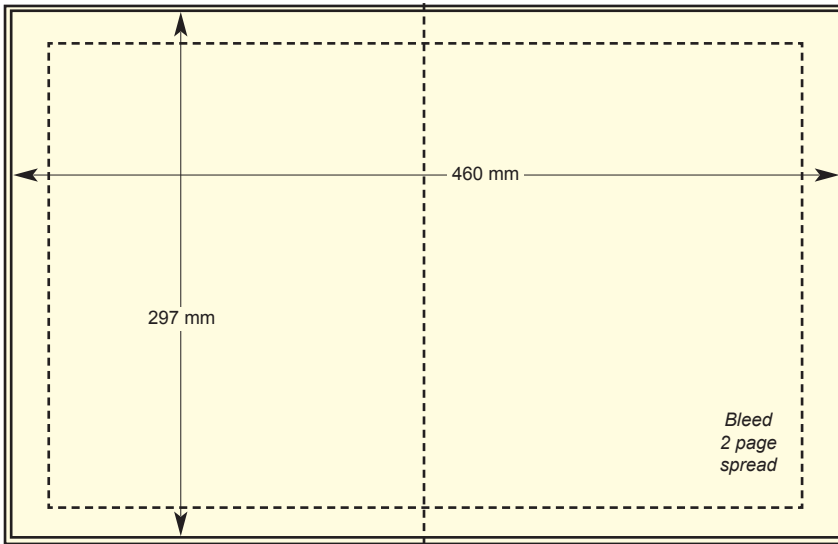

### Double Page Spread

Bleed: 303 mm x 466 mm  
Trim: 297 mm x 460 mm

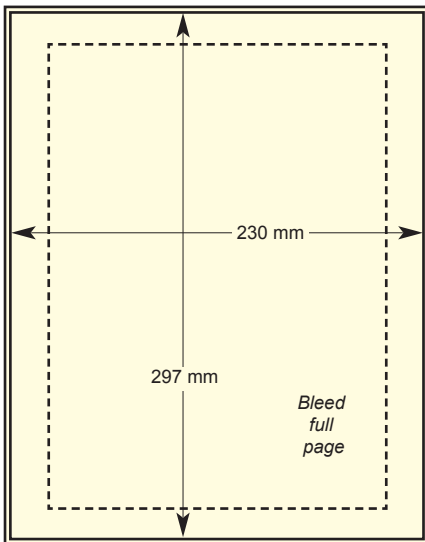

### PERFECT BINDING:

Please be aware that all of our magazines are perfect bound. It is the designer's responsibility to include double gutter image allowance if it is required. Also, we recommend that no type, logo or any important matter should appear within 8mm either side of the gutter on any spread to avoid being obscured.

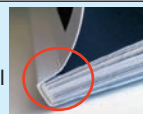

### Full Page

Bleed: 303 mm x 236 mm  
Trim: 297 mm x 230 mm

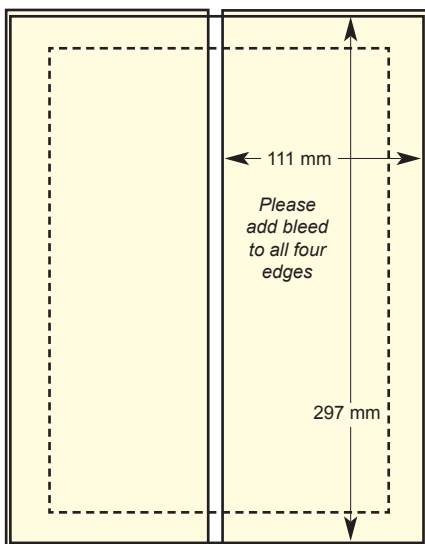

### Half Page Vertical

Bleed: 303 mm x 118 mm  
Trim: 297 mm x 112 mm

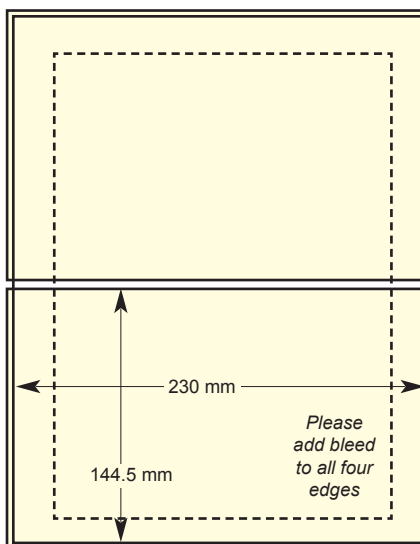

### Half Page Horizontal

Bleed: 151 mm x 236 mm  
Trim: 145 mm x 230 mm

## COPY REQUIREMENTS

We require that all copy be supplied only in digital format, and as specified below.

### ACCEPTABLE FORMATS:

- **Print Optimised (high resolution) PDF to PDF/X-1a:2001 standard, otherwise,**
- **High-resolution CMYK flat bitmap file (eg TIFF, PSD or JPG format)**
- Please always include crop marks and 3mm of bleed on ALL FOUR EDGES
- Max ink coverage = less than 290%
- If you use ICC profiles, please set your output to FOGRA39 (ISO 12647-2:2004)
- Please do **NOT** send us live files such as InDesign, Illustrator or Quark documents

**IMPORTANT:** All artwork must be converted to CMYK before sending. In all instances where colour fidelity is critical, a certified colour match is required two weeks prior to printing.

### DELIVERY to the Production Dept:

For files up to 25Mb (approx) in size

- Send your PDF file/s by email to: [production@unionpress.co.uk](mailto:production@unionpress.co.uk)

For files over 25Mb in size:

- We would recommend use of one of the free-of-charge online services such as **wetransfer, hightail, sendspace, dropbox** or any other such similar site.

We will check and preflight supplied files against our standard print profiles and return a summary acknowledgement of receipt and suitability for use. If problems are found in any files we will contact the sending party to make amendments.

PRODUCTION CONTACT: Mile Budimir | direct: +44 (0)20 7803 2456 | mobile: +44 (0)7388 876515 | email: [production@unionpress.co.uk](mailto:production@unionpress.co.uk)

# Technical specifications for THE SPIRITS BUSINESS

**PLEASE REMEMBER TO SEND A LINK WITH YOUR ARTWORK – AT LEAST HALF OF ALL BANNERS ARE SUBMITTED WITHOUT ONE AND IT IS, BY FAR, OUR MOST COMMON REASON FOR DELAY...**

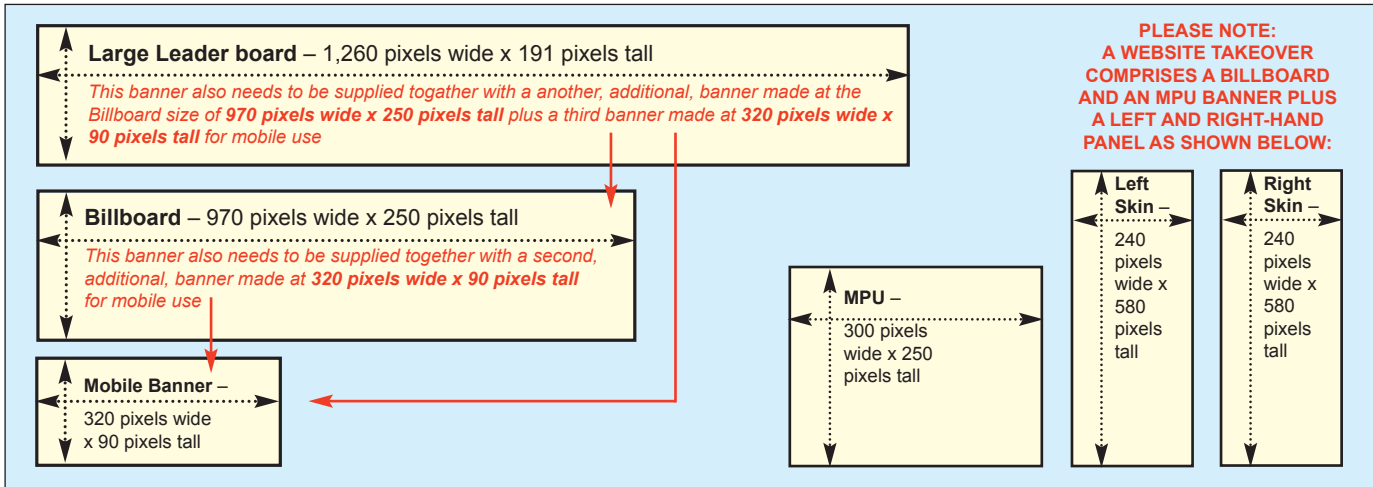

## ONLINE ADVERTISING SPECIFICATIONS:

### WEBSITE BANNERS AND BUTTONS:

Banner Description	Dimensions (width x height)	Maximum file size	Acceptable file types & technical notes <i>(Please note Flash-based adverts are no longer supported anywhere)</i>
<b>Large Leaderboard *</b>	1,260 pixels x 191 pixels	200Kb	JPG, PNG, GIF, HTML5**, Third-party tag <i>(see sizing note below)</i>
<b>Billboard *</b>	970 pixels x 250 pixels	200Kb	JPG, PNG, GIF, HTML5**, Third-party tag <i>(see sizing note below)</i>
<b>MPU (Mid Page Unit)</b>	300 pixels x 250 pixels	200Kb	JPG, PNG, GIF, HTML5**, Third-party tag
<b>Button</b>	150 x 150 pixels	200Kb	JPG, PNG, GIF
<b>Mobile</b>	320 pixels x 90 pixels	200Kb	JPG, PNG, GIF, HTML5**, Third-party tag

**Site Takeover** A site takeover is a combination position that includes a **Billboard**, **MPU** and **TWO side panels** that will follow the viewers progress up and down the page. As a result, we need to get hold of the following sizes of artwork:  
 1 x **Billboard**: 970 pixel wide x 250 pixel tall + an additional 320 pixel wide x 90 pixel tall mobile version  
 1 x **MPU**: 300 pixel wide x 250 pixel tall  
 2 x **Side panels**: 240 pixel wide x 580 pixel tall (left-hand side) + 240 pixel wide x 580 pixel tall (right-hand side)

### PLEASE NOTE:

\* **Large Leaderboard & Billboard banner positions** need to be supplied together with additional banners in order to work. When supplying artwork for the **Large Leaderboard** we need **THREE banners** – made at **1,260 x 191 pixels**, **970 x 250 pixels** and **320 x 90 pixels**. When supplying artwork for the **Billboard** we need **TWO banners** banners – made at **970 x 250 pixels** and **320 x 90 pixels**.

\*\* **HTML5** can be supplied as third-party tag, DoubleClick Studio creative, DCM tag or as self-contained HTML5 in a single-code snippet. Where artwork is run as HTML, we would request that you respect our audience experience and refrain from using pop ups, pop unders, ad pushdown or any above page, floating or between layer windows. Audio and video can be used in banner as a third-party tag streaming from your video provider with stop, pause, play and audio control buttons required. HTML banners should not exceed 15 file requests during initial file load and host-initiated subload and all files for the banner (.html, .js, .css, images, etc.) must be included as part of the maximum file weight calculation for all file load limits.

### NEWSLETTER BANNERS AND BUTTONS:

Banner Description	Dimensions (width x height)	Maximum file size	Acceptable file types
<b>Main Body Banner</b>	632 pixels x 90 pixels	200Kb	JPG, PNG, GIF
<b>Button</b>	150 x 150 pixels	200Kb	JPG, PNG, GIF

### PLEASE NOTE:

It is not possible to run or embed assets that require server-side technologies within an email newsletter; we only support static files in JPG and PNG format and animations in GIF format. Furthermore, please be aware that certain email clients deliberately stop GIF animations for security reasons (eg, some versions of Microsoft Outlook) and only show a static image (for more explanation: <https://support.microsoft.com/en-us/office/the-animated-graphic-in-my-e-mail-message-doesn-t-work-a5e8a2a3-9d86-4203-8920-c88cb8739e34>) as a result we would recommend keeping all of the most important information in the first frame of your animation.

### ARTWORK DELIVERY:

Please submit your completed artwork to: **isabel.distin@unionpress.co.uk** for initial checking and pre-approval. On completion we will return a summary acknowledgement of receipt and suitability for use. However, if problems are found in the supplied files we will contact the sending party to make them aware of the issue and may suggest amendments. We will always do our best to ensure that artwork will work across all browsers and platforms, but cannot make any guarantees in material supplied to us.

**PRODUCTION CONTACT: Isabel Distin** | mobile: +44 (0)7922307844 | email: [isabel.distin@unionpress.co.uk](mailto:isabel.distin@unionpress.co.uk)

## CONTACT SALES & EVENTS

### **Richard Cochrane**

Managing Director  
Tel: +44 (0) 207 803 2449  
Mob: +44 (0) 7887 606866  
Email: richard.cochrane@thespiritsbusiness.com

### **Ryan Graves**

Deputy Managing Director  
Tel: +44 (0) 207 803 2424  
Mob: +44 (0) 7527 362 471  
Email: ryan.graves@thespiritsbusiness.com

### **Rhiannon Morris**

Sales & Marketing Manager  
Tel: +44 (0) 207 803 2430  
Email: rhiannon.morris@thespiritsbusiness.com

### **Melissa Crawley**

Sales Executive  
Tel: +44 (0) 207 803 2420  
Email: melissa.crawley@thespiritsbusiness.com

### **Sophie Allan**

Events Director  
Tel: +44 (0) 207 803 2442  
Email: sophie.allan@thespiritsbusiness.com

### **Peter Everall**

Global Wine & Spirits Masters Manager  
Tel: +44 (0) 772 555 9880  
Email: peter@thedrinksbusiness.com

## CONTACT EDITORIAL

### **Melita Kiely**

Editor-in-Chief  
Tel: +44 (0) 207 803 2436  
Email: melita.kiely@thespiritsbusiness.com

### **Nicola Carruthers**

Deputy Editor  
Tel: +44 (0) 207 803 2444  
Email: nicola.carruthers@thespiritsbusiness.com

### **Georgie Collins**

Digital Editor  
Tel: +44 (0) 207 803 2433  
Email: georgie.collins@thespiritsbusiness.com

### **Lauren Bowes**

Bars Editor  
Tel: +44 (0) 207 803 2420  
Email: lauren.bowes@thespiritsbusiness.com

### **Rupert Hohwieler**

Senior Staff Writer  
Tel: +44 (0) 207 803 2425  
Email: rupert.hohwieler@thespiritsbusiness.com

### **Miona Madsen**

Content Writer  
Tel: +44 (0) 207 803 2420  
Email: miona.madsen@thespiritsbusiness.com